

# PRIMINER

**EMIL** Sp.A.  
**MACCHINE  
UTENSILI**  
Importazione - Distribuzione - Service



## C500-5X

### 5 Axis Machining Center

High rigidity, High efficiency



# APPLICATIONS

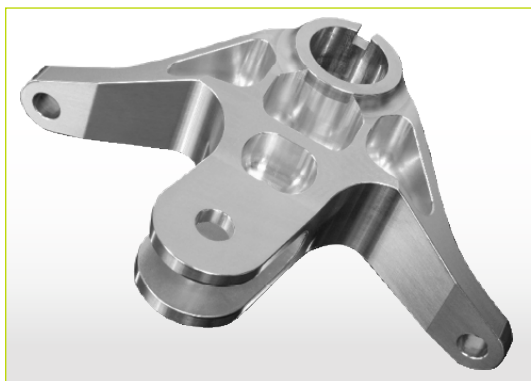
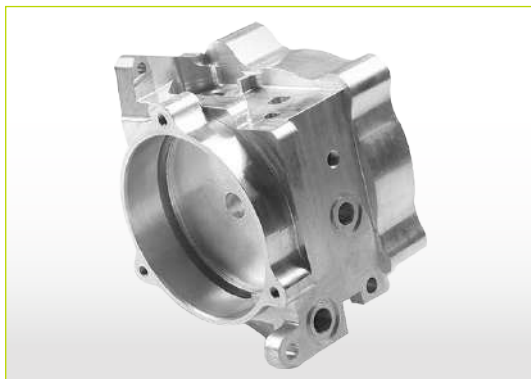

- Die casting
- Medical

- Structural components
- Mould parts

- Tooling
- Aerospace

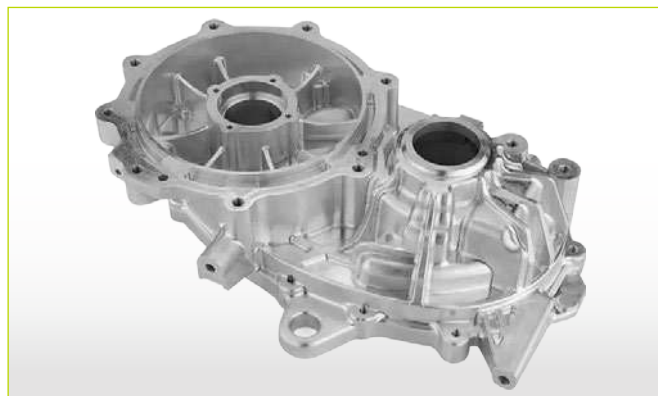
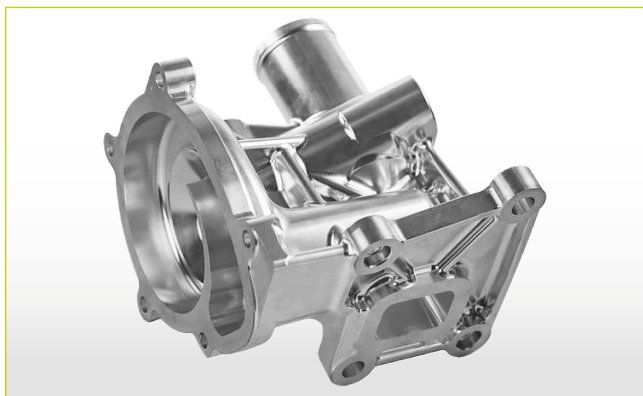

# C500-5X

Cost-effective entry into the 5 -sided and 5 axis simultaneous machining

- X/Y/Z axis movement are separated from the machining area
- Dual-support rotary table, high rigidity, high performance and efficiency
- A/C axis with roller gear cam drive
- X/Y/Z axes optional with direct measuring system
- A/C axis optional with rotary encoder

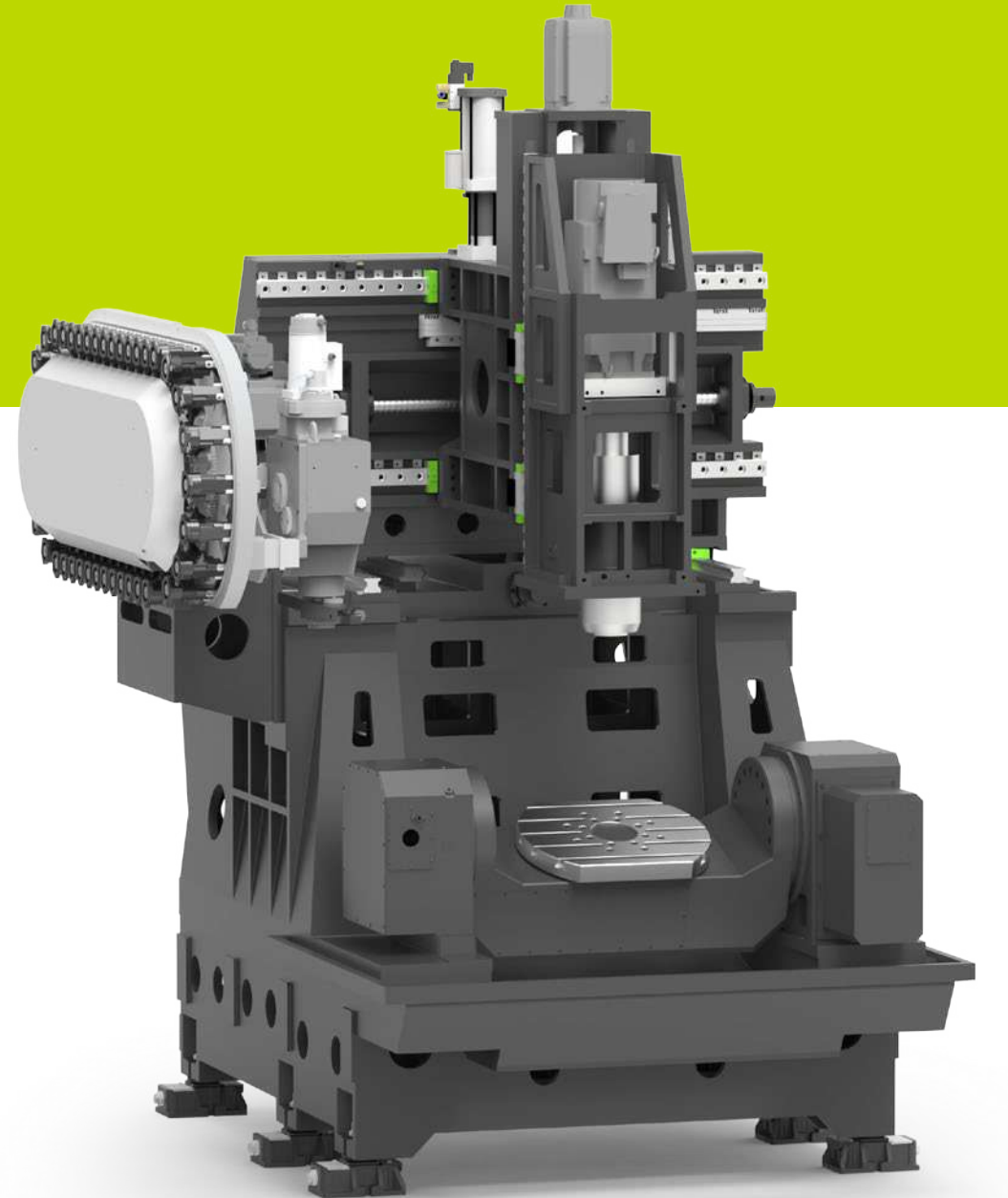

# A/C AXIS WITH ROLLER GEAR CAM DRIVE

- Roller gear cam drive rotary table
- A/C axis rotation speed 50/60 rpm
- A axis travel +30°~ -120°
- C axis travel 360°

## Machining dimensions

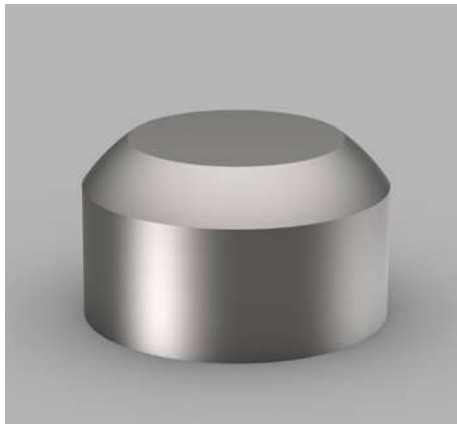

- Max. workpiece diameter 700 mm
- Max. workpiece height 500 mm
- Max. workpiece weight 255 kg

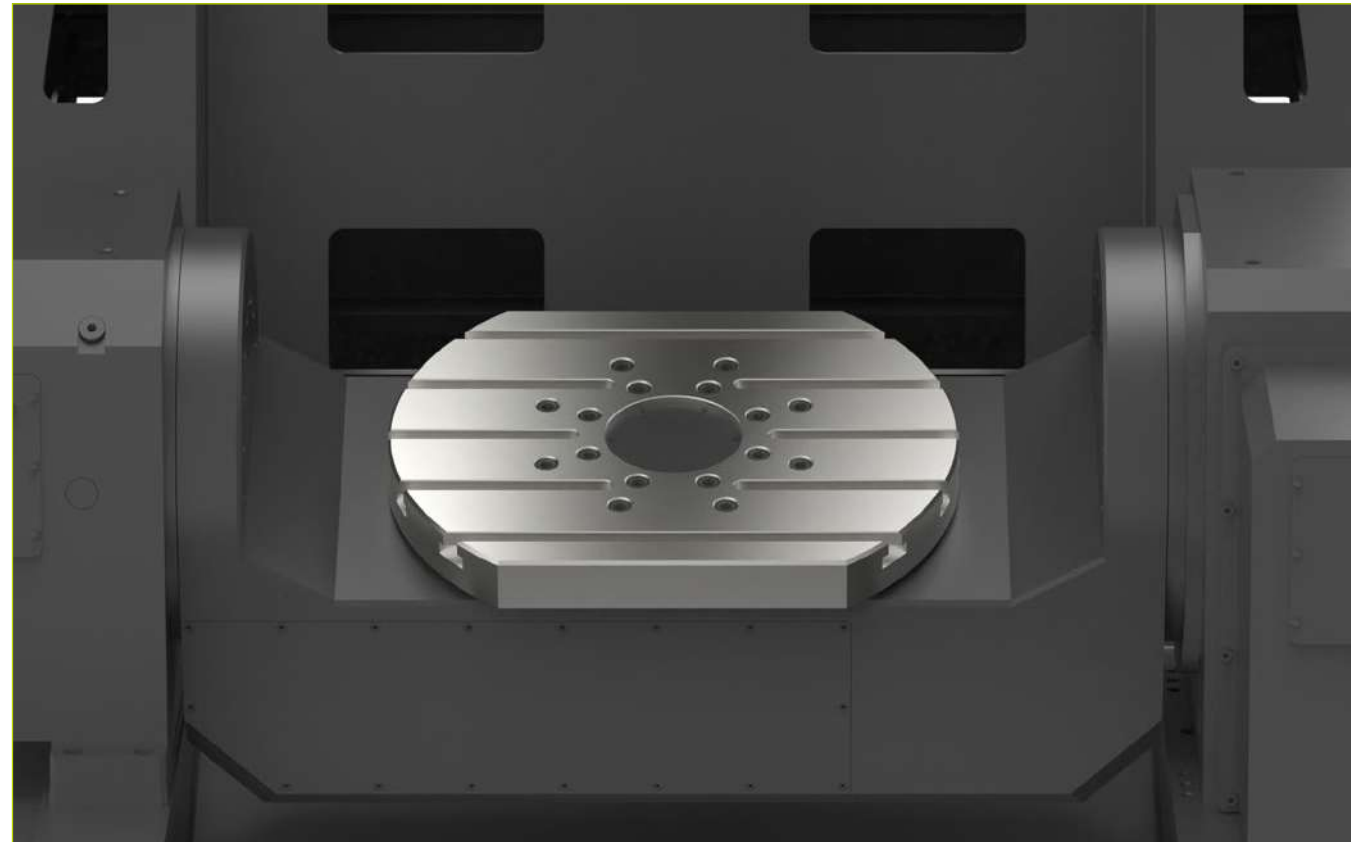
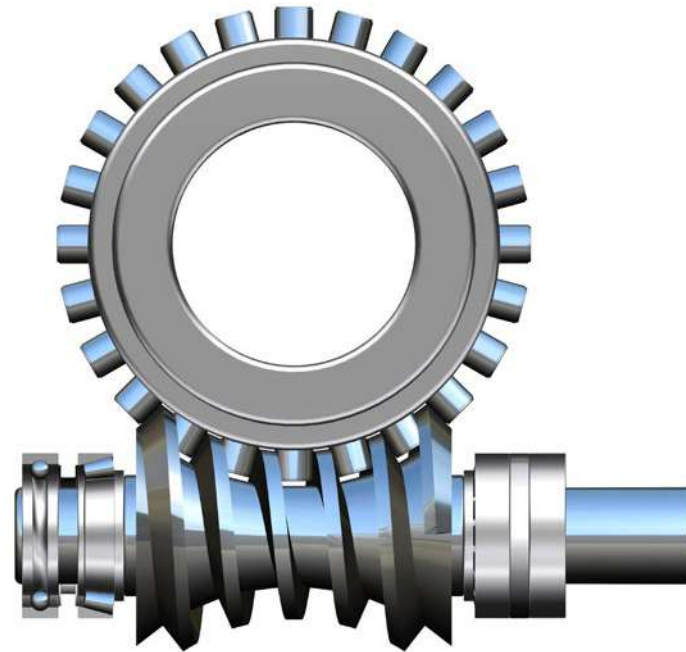

# CHAIN TYPE TOOL CHANGER



- Tools can be loaded and unloaded while machining
- User-Friendly interface make the loading and unloading of the tools easier
- High production efficiency

## Technical Specification:

- 40 pockets ( Opt.60 pockets)
- Max.tool length 300 mm
- Max.tool diameter  $\Phi$  80/ $\Phi$  125mm
- Max.tool weight 8 kg



# HIGH-PERFORMANCE SPINDLE

## Power and torque diagram

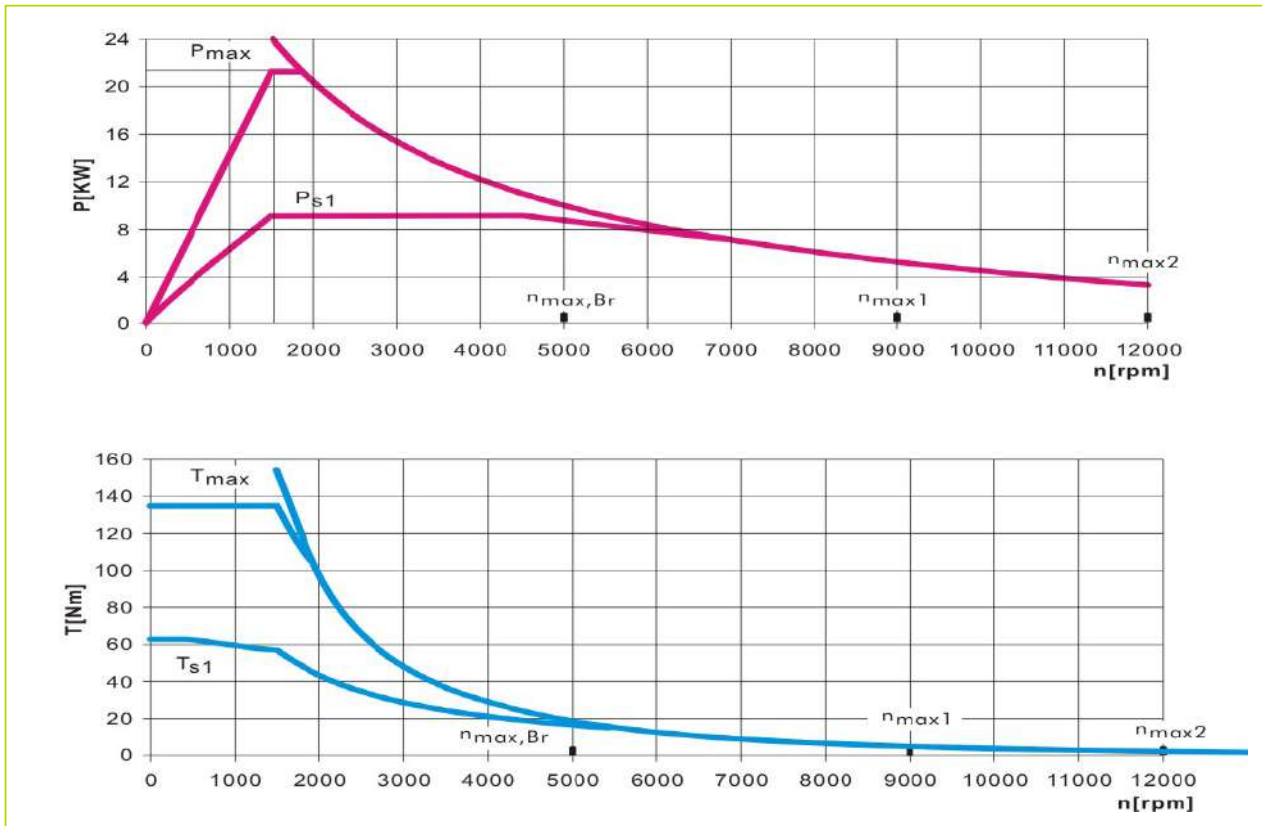

**BBT40 · 12000 rpm 9/22 kW (S1/S6) 63/135 Nm (S1/S6)**

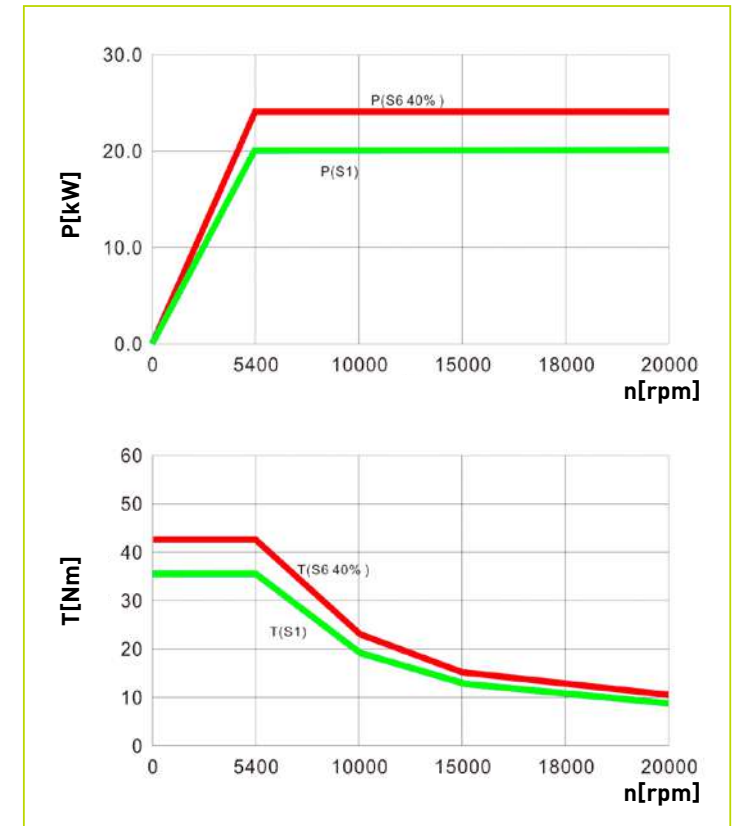

**HSK A63 · 20000 rpm 20/24 kW 35/42 Nm**



# HEIDENHAIN TNC 640

The TNC contouring control for milling and milling-turning machines

**Key features:**

## Intelligent-Dynamic Precision Machining

- ✓ Dynamic Collision Monitoring (DCM)
- ✓ Dynamic Efficiency
- ✓ Active Chatter Control (ACC)
- ✓ Adaptive feed control (AFC)
- ✓ Machine any contour slot with trochoidal milling

## Fast and reliable machining at high contour fidelity

- ✓ Optimal tool guidance by the TNC 640

## Programming, Editing, Testing and Automated machining

- ✓ A full range of possibilities with the TNC 640
- ✓ Graphical support in any scenario
- ✓ Straightforward function keys for complex contours
- ✓ Programming free contours and Data Matrix codes
- ✓ Easy calibration of rotary axes with KinematicsOpt

## Tool measurement and Workpiece measurement

- ✓ Measuring length, radius, and wear inside the machine
- ✓ Setup, preset setting, and measuring with touch trigger probes
- ✓ Machining and measuring 3-D contours
- ✓ The TNC 640 makes setup easy

## Open to outside information

- ✓ Processing CAD files with the TNC 640
- ✓ The TNC 640 programming station
- ✓ Uniformly digital job management with Connected Machining
- ✓ Machining and measuring 3-D contours
- ✓ The TNC 640 makes setup easy



# SIEMENS SINUMERIK 828D

The perfect solution for all performance classes

## New Panel Processing Unit

- ✓ Higher processor performance
- ✓ Digital Input with higher voltage stability
- ✓ 1GB Ethernet interface X130
- ✓ Pull-relief for the DRIVE-CLiQ and PN cables
- ✓ More robust touch-operation 15,6" PPU290.4

## Features for milling Cogging torque compensation and 2nd channel for milling

- ✓ System integrated function
  - Drive-based function SINAMICS
- ✓ Automatic measure of the cogging torque
- ✓ Pre-control of periodic repetitive torque ripple
- ✓ Function available for rotative-, linear- and torque motors
- ✓ 2nd Channel Milling
  - For both machining and handling & robot purpose

## Nodding Compensation ECO/Advanced and Advanced Position Control ECO

- ✓ Intelligent control based compensation
  - New developed compensation algorithm
- ✓ System integrated function
  - As a CNC and HMI feature
- ✓ Scalable function in 3 steps
  - ECO
  - Advanced
  - Compile Cycle
- ✓ Commissioning support with HMI masks
  - Additional input mask from SINUMERIK Operate

## Higher speed, more accurate for the entry level

## Tool Ident Connection

## Jerk Adapation

## Top Speed plus

## Intelligent Load Control (ILC)

## Intelligent Dynamic Control (IDC)



## Standard configuration

- Roller gear cam drive rotary table
- Full enclosed splash guard
- Direct drive spindle 12000rpm, BBT40
- 40 pockets chain type tool changer
- Chain type chip conveyor
- Spindle oil cooler
- Air-conditioned electrical cabinet
- Rigid tapping
- Ethernet, CF card and USB interface
- Automatic lubrication system
- Coolant system
- Air blast during cutting
- LED working lamp
- End of program light
- Electrical handwheel (MGP)
- Tool box
- Leveling bolts and blocks
- Coolant gun
- Air gun
- User manual

## Optional configuration

- Direct drive spindle 15000rpm, BBT40
- Direct drive spindle 15000rpm, HSK A63
- Built-in spindle 20000rpm HSK A63
- 60 pockets chain type tool changer
- CTS Coolant Through Spindle + ATS
- Linear scales on X/Y/Z axis
- Rotary encoder on A/C axis
- Workpiece probe
- Tool probe
- Dynamic Collision Monitoring (DCM)
- Oil mist collector
- Oil skimmer
- Extra 200GB SSD program memory

## Technical Specifications

Table	
Max. workpiece diameter	Φ700 mm
Table size	Φ500×400 mm
T-slot (width x number x distance)	14 mm×80 mm×5
Max. load	255 kg
Travel	
X/Y/Z Travel	700 / 550 / 500 mm
A/C Travel	+30°~-120°/360°
Spindle nose to table	120-620 mm
Spindle	
Spindle taper	BBT40, 12000 rpm
Spindle motor power	9/22 kW, 63/135 Nm
Feed	
Rapid feed X/Y/Z	48 m/min
Rotation speed A/C	50 / 60 rpm
Cutting speed	1-12000 mm/min

Tool changer	
Number of tools	40 pcs
Max. tool length	300 mm
Max. tool diameter	Φ 80 / Φ 125 mm
Max. tool weight	8 kg
Accuracy(VDI 3441 Full travel)	
Positioning accuracy X/Y/Z axis	0.008 mm
Repeatability accuracy X/Y/Z axis	0.006 mm
Positioning accuracy X/Y/Z axis (With linear scales)	0.006 mm
Repeatability accuracy X/Y/Z axis (With linear scales)	0.004 mm
Dimensions & Weight	
Dimensions	3976×4965×3250 mm
Weight	7000 kg

# CUTTING AREA

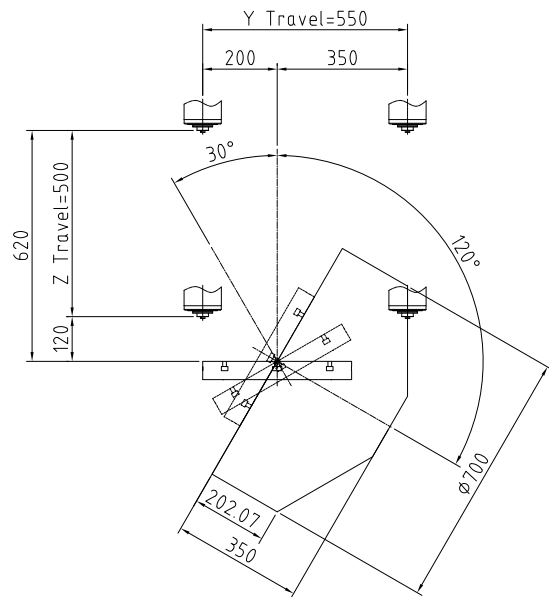
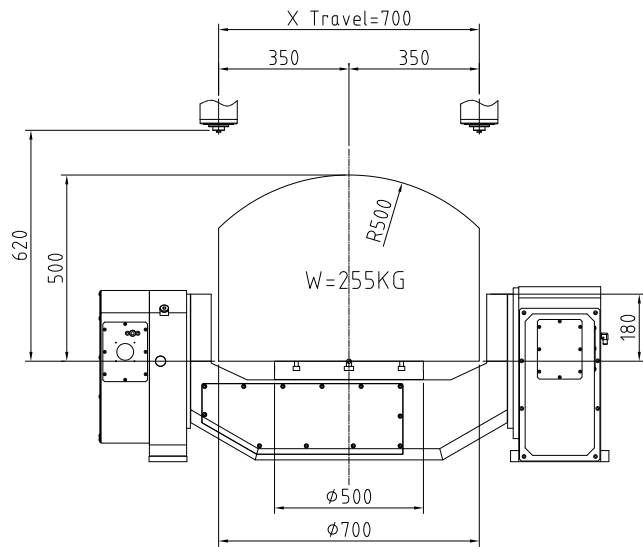

# DIMENSIONS

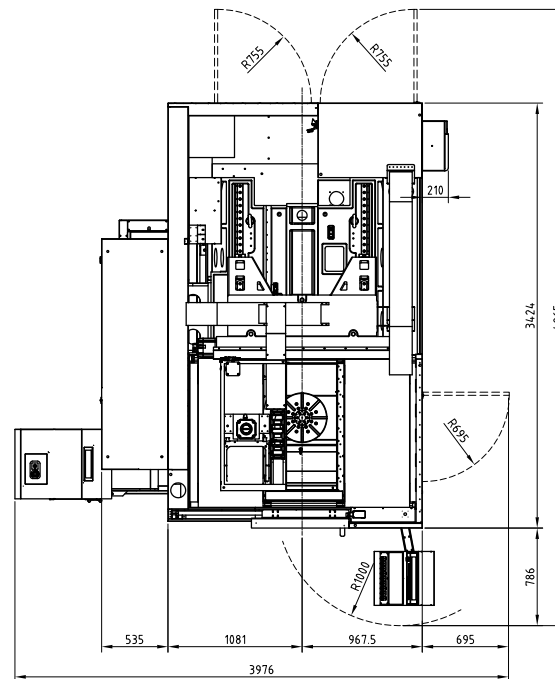
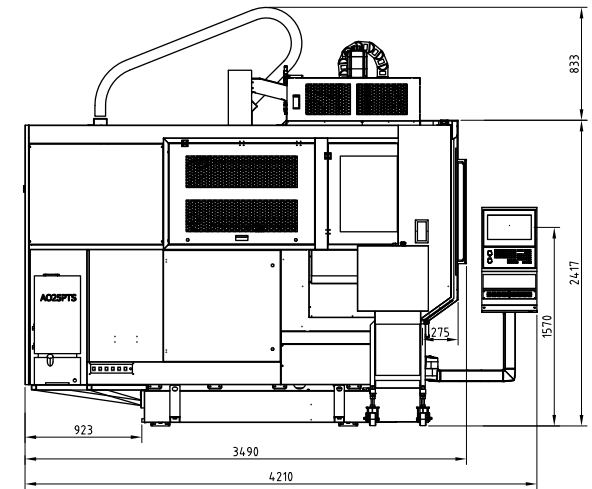
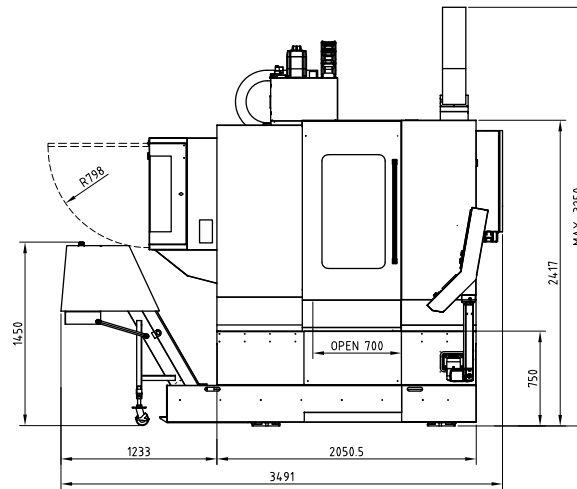

*C'è vero progresso solo  
quando i vantaggi di una  
nuova tecnologia diventano  
per tutti.*



Via Bulgaria, 24

41122 Modena, IT

Tel.: +39 059 311574

Fax: +39 059 454338

 emilmacchineutensilisl

*Per informazioni commerciali:*

vendite@emusrl.com

*Per assistenza e ricambi:*

service@emusrl.com

ricambi@emusrl.com

info@emusrl.com

www.emilmacchineutensili.it



**PRIMINER** 

 **EMIL** S.p.A.  
**MACCHINE  
UTENSILI**   
Importazione - Distribuzione - Service